

# ***TYRE CHANGER***

***READ THIS ENTIRE MANUAL  
BEFORE OPERATION BEGINS***

RECORD HERE THE FOLLOWING INFORMATION  
WHICH IS LOCATED  
ON THE SERIAL NUMBER DATA PLATE

Serial No. \_\_\_\_\_

Model No. \_\_\_\_\_

Manufacturing date. \_\_\_\_\_

# INDEX

<b>Important safety instructions</b>	1
<b>Preface</b>	1
<b>Information</b>	1
<b>Brief Introduction</b>	1
<b>Technical data</b>	2
<b>Structure</b>	2
<b>Warning stickers and instruction of the machine</b>	3
<b>Installation for semi-automatic machine</b>	3
<b>Installation for completely automatic machine</b>	4
<b>Maintenance</b>	4
<b>Instructions for the operation</b>	5
<b>Demounting</b>	5
<b>Mounting</b>	6
<b>Inflating</b>	7
<b>Inflate tires with IT system</b>	7
<b>Transport</b>	7
<b>Electrical diagram</b>	7
<b>Adjustment for dual- locking machine</b>	8
<b>Adjustment for the completely automatic machine</b>	9

# **IMPORTANT SAFETY INSTRUCTIONS**

Read these safety instructions entirely!

Read and understand all safety instructions before operating machine

## **Preface**

Thanks for choosing this tire changer. This machine is designed and made specially for changing the tires of automobile and motorcycle with the principle of best quality and highest working efficiency. For ensuring correct and safe operation, and prolonging the work life of the machine, please read this manual carefully.

## **Information**

Information about tire changer, such as type, specifications and related data, are helpful for service technician to provide technical service and parts replacement.

For convenient understanding, this manual contains the relevant information about the machine. Should there be any difference between the data in this manual and that on the nameplate, take the data on nameplate as correct one.

Carefully keep this manual for use at any time.

## **Brief Introduction**

### **Scope of Application**

This tire changer is specially designed for removing tire from rim and installing tire onto rim.

**Note: This machine can only be used for the purpose designed by the manufacturer. Do not use it for any other purpose.**

Any damage caused by incorrect use will not be covered under warranty.

### **Safety Regulations**

Only the trained and qualified operators can be allowed to operate the machine. Unauthorized change of parts or nonobservance of instruction may cause machine damage.

## 1. Technical Data

### Applicable Range

Max.wheel width:330mm

Max.wheel diameter:920mm

Outside locking(RIM):(10" —18" ) (10" —20" )

Inside locking(RIM): (12" —21" ) (12" —23" )

### motor

Power supply:110V / 220V/380V 50/60HZ

Electric motor: 1.1kw/0.75kw

### Weight

Net weight:185kg

### Air device

Operating pressure: 8-10bar

Moving grip inside(RIM):8" —20"

Moving grip outside(RIM):10" —22"

RPM of turntable:7rpm

Phase: Single/Three

### working conditions

working temperature:0-45°C

## 2. Structure

Operation parts of semi-automatic, single- locking machine(Fig.1)

- 1、 Single- locking handle
- 2、 Mount/demount head
- 3、 Bead lifting tool
- 4、 Front logo
- 5、 Gun inflator
- 6、 Turntable
- 7、 Cylinder
- 8、 Turntable control pedal (clockwise or counter clockwise)
- 9、 Clamp control pedal
- 10、 Tire control pedal
- 11、 Bead breaker shoe

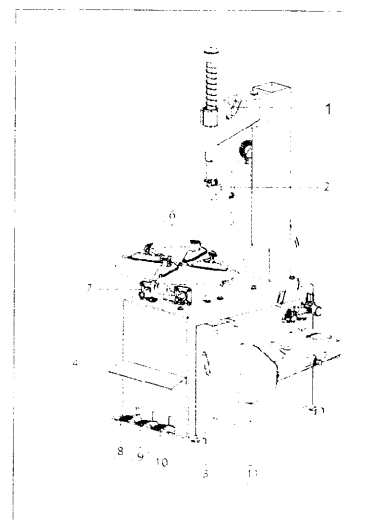

(Fig.1)

Operation parts of semi-automatic, dual- locking machine(Fig.2)

- 1、 Dual- locking handle
- 2、 Mount/demount head
- 3、 Bead lifting tool
- 4、 Front logo
- 5、 Gun inflator
- 6、 Turntable
- 7、 Cylinder
- 8、 Turntable control pedal (clockwise or counter clockwise)
- 9、 Clamp control pedal
- 10、 Tire control pedal
- 11、 Bead breaker shoe

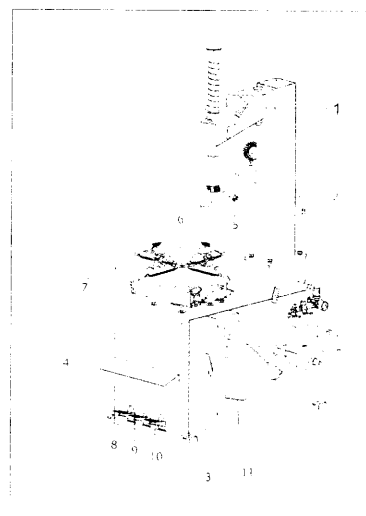

(Fig.2)





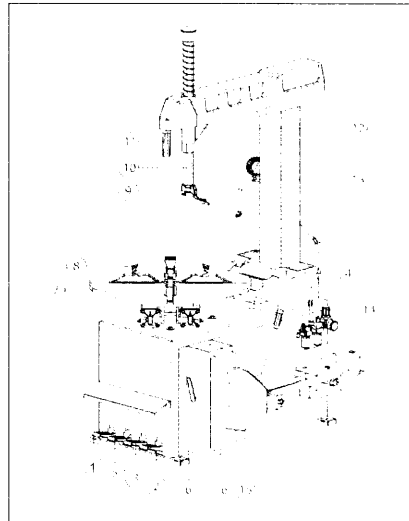

Operation parts for completely automatic machine (Fig.3)

1. Pedal for tilting the mounting column
2. Pedal for rotating the clamping chuck
3. Pedal for pressing the tire
4. Tool box
5. Pedal for expanding the jaws
6. Tire crowbar
7. Clamping chuck
8. Jaw
9. Mount/demount head
10. Vertical shaft
11. Lock lever
12. Horizontal arm
13. Air pressure gauge
14. Air valve
15. Bead breaker shoe
16. Rubber pad



(Fig.3)

### Warning stickers and instruction of the machine

-  Never place leg between the bead breaker shoe and bead breaker rubber, avoid stepping the wrong pedal and cause injury of the operator.
-  Never place hand on the tire when the demount head is on the working position, avoid the injury of the operator.
-  Never place your hand between the tire and gripping device when operate the rim, avoid the injury of the operator.
-  The jaws should in closed position but not in open position when do the bead break, avoid the injury of the operator.
-  The operator should wear the protection glasses when inflate the tires with the machine with GT system, avoid something blow into eyes.
-  Never put hand between the rim and tire when inflate the tire, avoid the injury of the operator.
-  There should be nobody behind the tilting pole, when the machine is on the working position.

### Installation for semi-automatic machine (Fig.4)

#### SPACE REQUIRED

When choose the place for installation be sure that it complies with current safety regulations.

The semi-automatic tire changer must be connected to the main electric power supply and air compressed system. It is therefore advisable to install the machine near these power sources.

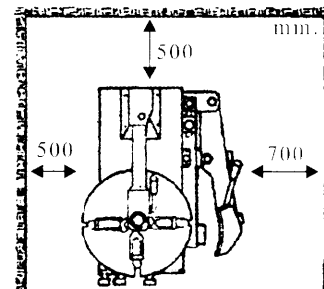

( Fig.4 )

The place of installation must provide at least the space shown in figure 4, so as to allow all parts of the machine to be operated correctly and without any restriction.

If the machine is installed outside, it must be protected by a lean-to.

→ **The tire changer with electric motor can't be used in explosive atmospheres, unless it is a proper version.**

## Installation for the completely automatic machine

Place the machine on the chosen place, then fix it to the ground by fixing screw. Lift the tilting arm, and insert the PU hose (G) into the hole (Fig.5). (Do not bend the hose) Then take out the part A (shown in Fig.5) from the accessory box, unscrew the cap on the top of part A, insert the part A into the hole that go through the main box of the machine and the bottom of the tilting arm, then tighten the bolt. Take out the part B (shown in Fig.5) from the accessory box, unscrew the spring on one side of part B, then insert part B into the hole that go through the part D, E, then screw the spring. Dismount the protection plate on the side of the machine. Connect the PU hose (G) that go through the main box of the machine with the part F.

After the above operation is finished, mount the part E on the arm (Fig.6), then mount parts D, C, B, A, G, F in sequence. During the operation, pay attention to the PU hose and other parts.

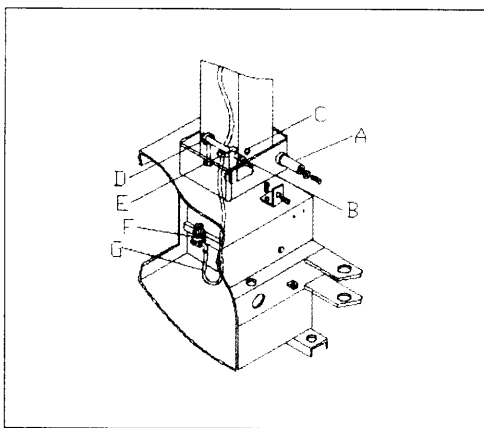

(Fig.5)

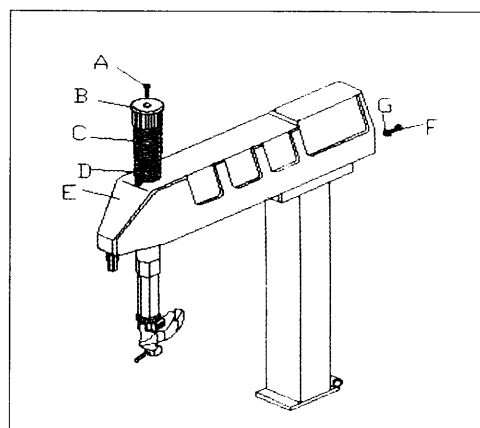

(Fig.6)

→ **Insert the expansion bolt into the hole at the bottom of the machine to fix the machine, or if it is not steady, it may cause noise and other problems.**

## Maintenance

The following maintenance must be done at least once every month.

→ **Only the specialized technician can do the maintenance.**  
→ **Before doing any maintenance, shut off power supply and air source.**

\*Check the oil level in the air-compressed cup periodically. If it needs to be filled, you must shut off air source, then fill the SAE30 oil.

\*Clean and lubricate all the moving parts of the turntable. (Fig.7)

\*Check all connecting parts and bolts periodically and tighten them if necessary.

\*Keep the hexagonal vertical axle clean and lubricate it periodically. (Fig 8)

\*Check and adjust the tension of the driving belt. (Fig.9)

\*Keep the machine and the working area clean to avoid the dust entering the moving parts.

\*Lubricate all the moving side of the machine weekly.

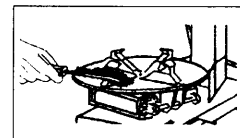

(Fig.7)

\*Prepare a water segregator near the air-compressor, to reduce the amount of the water in the air that go through the machine.

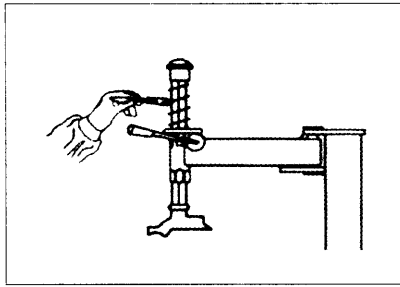

(Fig.8)

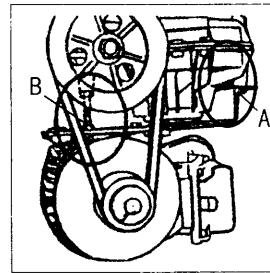

(Fig.9)

### Instructions for the operation

→ Only the trained person can do the operation of the machine.

### Demounting

1. Release all the air inside the tire.
2. Remove the balance block from the external side of the rim. (Fig.10)

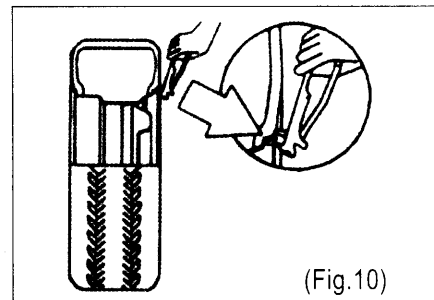

(Fig.10)

### Do the operation as follow:

1. Place the tire between the bead breaker shoe and rubber pad, and make the shoe between the bead and the tire, step on the tire control pedal (10), (in Fig2 step the pedal 10, and in Fig3 step the pedal 3) to separate the bead from the rim. (Fig.11)

→ Lubricate the bead with thick soap solution before demounting the tire, avoid the damage and facilitating the operation.

2. Repeat above steps on the other parts of the tire to get the tire separated thoroughly from the rim.
3. Set the vertical shaft in the working position, so that the mount/demount head is near the rim. The roller in the mount/demount head should be 2 mm from the rim to prevent scratching the rim. (Fig.12) Turn the lock lever to lock (automatic machine use locking handle 11 to lock the Fig .3)

→ Note: the angle of the mount/demount head is already calibrated according to the standard rim before delivery. The user can re-calibrate it with hexangular spanner for the overlarge or over small rim so as not to damage the tire.

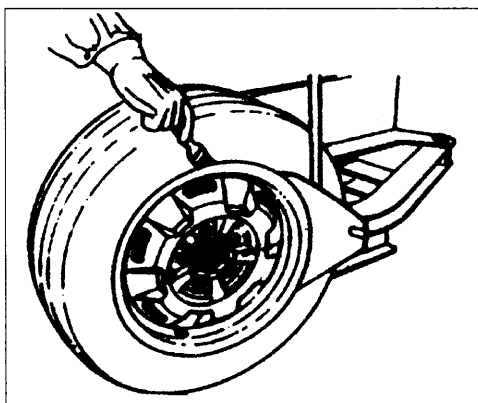

(Fig.11)

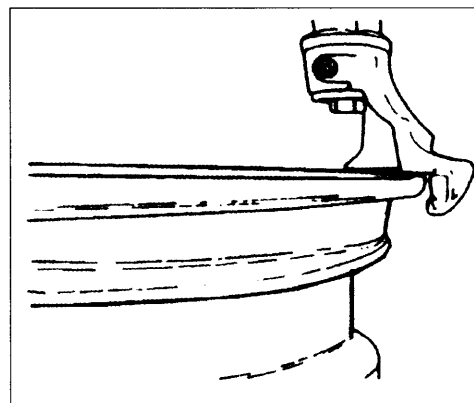

(Fig.12)

4. Lift the bead onto the mount/demount head with the bead lifting tool, and step on the turntable control pedal 8 (in Fig.2 step on the pedal 8 and in Fig 3 step on the pedal 2) to turn the turntable clockwise till the bead is completely separated (Fig.13), it is suggested to place the mount/demount head about 10mm to the right side of the air valve if the wheel has a tube, so as not to damage the tube.

**→ If the demounting is blocked, stop the machine at once, and pull up the pedal 8 (in Fig 2 pull up the pedal 8 and in Fig3 pull up the pedal 2) to turn the turntable counter-clockwise, so as to clear up the block.**

5. Take out the tube if there is. Turn over the wheel to let the other side toward the mount/demount head, and repeat the above steps to demount the other side of the bead. (Fig.14)

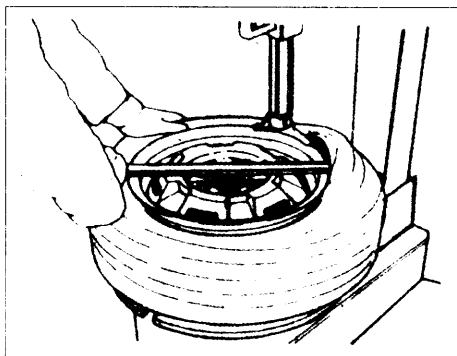

(Fig.13)

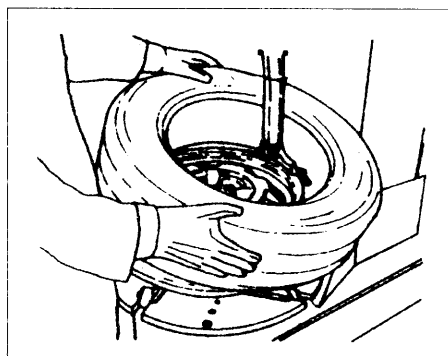

(Fig.14)

**→ Keep your hand and body away from the moving parts during the operation. It is very dangerous to wear necklace, bracelet or loose blouse for the operators.**

## Mounting (Fig15)

**→ Make sure that the size of the rim and tire is same before mounting.**

- 1 Clamp the rim on the turntable.
2. Lubricate the bead with soap solution.
3. Put the bead on the machine with the left side upward, and press down the tire simultaneously, and turn the turntable clockwise to let the bead enter the bead seat.
4. Cover the tube onto the rim if there is, and repeat the above steps to mount the upper side of the tire.

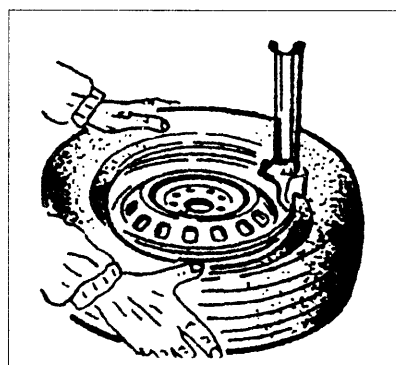

(Fig.15)

**→ It is not necessary to move the locking handle every time, if the size of the rims is the same, just move the horizontal swing arm.**

**→ Do not put your hand between the tire and swing arm during locking, so as to avoid body injury.**



## Inflating (Fig16)

This machine is equipped with a gauge for pressure reading during inflation.

1. Loose the tire from the turntable.
2. Connect the inflator with the air valve on the tire.
3. Press the gun inflator slowly for several times. Make sure the reading on the gauge does not exceed the manufacturer's limit.

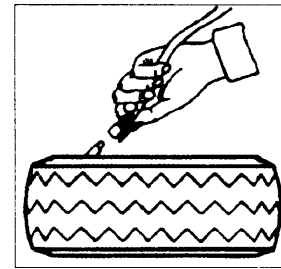

(Fig.16)

## Inflate tires with IT system

1. There is a pedal on the side of the machine. This pedal has two positions. The first position is for the inflation for the tire with tube. Step the pedal lightly for several times during the inflation. Make sure the reading on the gauge does not exceed the manufacturer's limit. (Fig.17)
2. The second position is for the inflation for the tubeless tire, step the pedal down fully to the bottom, and then make the pedal to the first position to continue the inflation. Make sure that the reading on gauge doesn't exceed the manufacturer's limit.

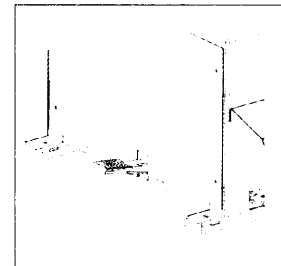

( Fig.17 )

**→ Keep your hand and body away from the moving parts during the operation, avoid the injury. Make sure the tire is not damaged before the inflation, and the pressure in the tire does not exceed 3.5 bar.**

## Transport

Make sure transport the machine with its original package, and place it according to the marks on the package. The packed machine should be moved by means of a fork lift truck of suitable capacity, insert the forks at the points shown in (Fig.18).

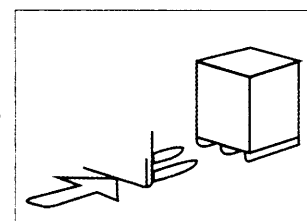

(Fig.18)

## Electrical diagram

- Make sure the machine is connected with the ground before the operation.
- The operation of the electricity must be done by the authorized operators.
- Make sure the steady of the external power supply, if the rated power is 220v, so as to avoid the damage of the electric capacitor.

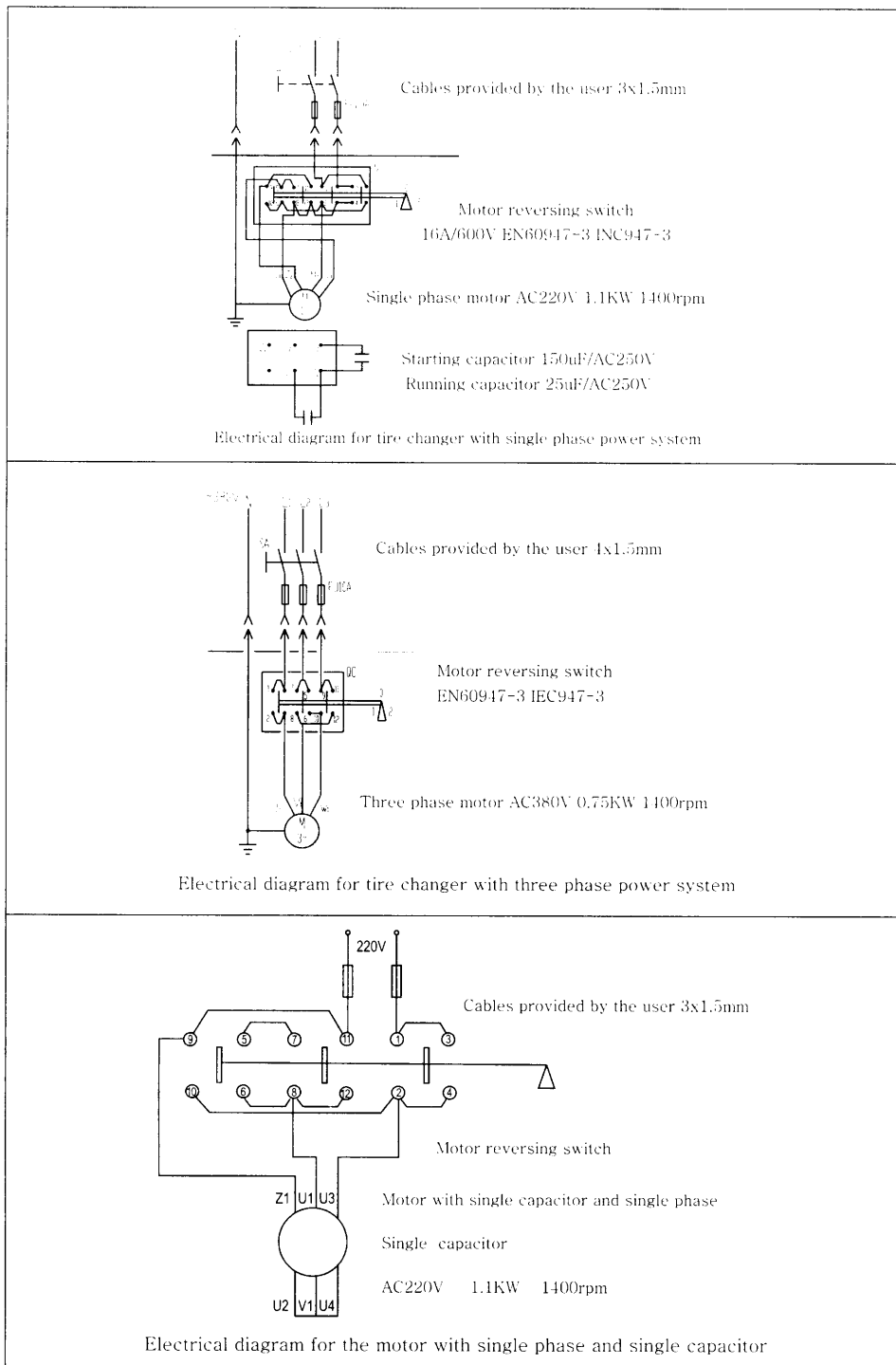

### Adjustment for dual-locking machine (Fig.19)

→ The machines have been calibrated before delivery by trained operator, so don't adjust it at random.  
If the horizontal arm does not lock well, do the adjustment as following steps.

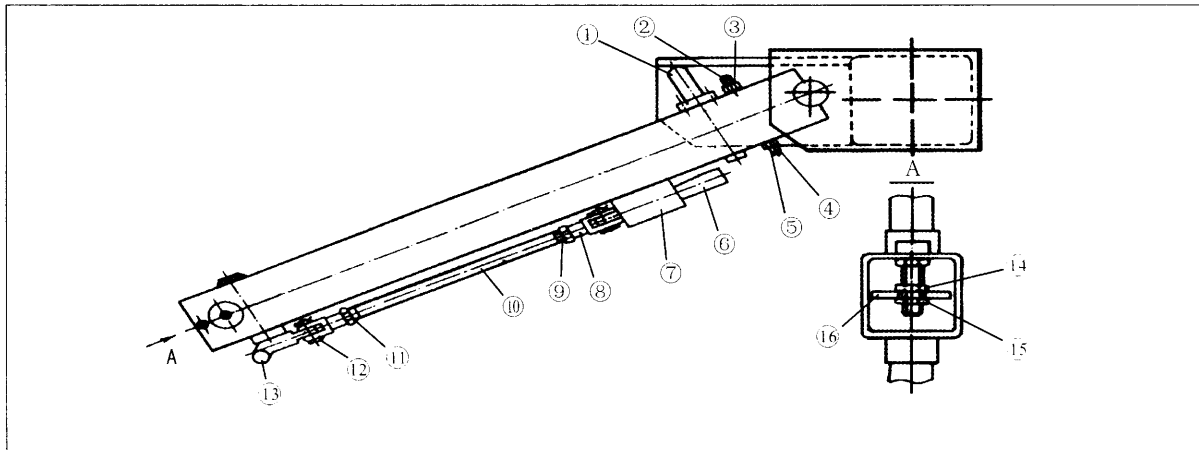

(Fig.19)

### The adjustment for the hexangular vertical shaft

Adjust the nut (14) and (15) lightly until it lock well.

### The adjustment for the fixing shaft of horizontal arm

- \*Turn the handle (13) to the position shown as the figure, make the cross adapter (8) reach the fixed plate (7).
- \*Turn the swing arm to the outside fully, then loose the nut (3), and loose the screw (2) about 20mm.
- \*Push the fixed shaft (1) by hand to make it slide freely, then rotate the screw (4) out slowly, till the extreme position of fixed shaft (1), then tighten the nut (5).
- \*Tighten the screw (2) fully, and turn one circle back, then tighten the nut (3).
- \*If it still does not lock well after the above steps, loose the nuts (11), (9), then rotate the bolt (10) to make it short, then tighten the nuts (11), (9), the fixed shaft (1) will lock well.

### The adjustment for the completely automatic machine

#### Do the adjustment as follow steps, if the vertical shaft does not lock well.

Shut off the pneumatic supply, demount the vertical shaft cover, then adjust the nut near the thread rod by spanner, or lock the screw in front of the plate, then connect the pneumatic supply and observe the locked position.

#### Do the adjustment as follow steps, if the horizontal arm does not move smoothly, or not lock well.

Remove the cover on the tilt column, adjust the screw M6 on two sides by spanner, meanwhile push the horizontal arm till it can move smoothly, then tighten the nut and adjust the screw in the middle by spanner, lock the horizontal arm and observe the change, till it can only move in the range of 2mm, then lock the nut.

→ Read the user's manual and technical data according to the type of the machine. The users will not be informed, if this manual has some changes.