

9,000lb capacity 4 Post Lift Installation Manual

Parts Checklist

1	Main side track with 9/16" hole on cylinder end complete with cylinder, hose and connector
1	Offside track
2	Cross Rails pre-assembled with pulleys, pulley covers, and slider blocks
4	Columns with top caps and bolts
2	Short rods with heim ends
1	Long rod with heim ends
1	½" x 50" Bent Rod
4	Ramp Clips
4	Removable Wheel Stop
	FP9K cables with hardware
1	8' 7" Cable //
1	13' 2 5/8" Cable //
1	21' 10" Cable //
1	26' 6" Cable //
1	86" Hose with anti-kink spring and fittings
2	18" x 80" Plastic Sheets
1	Power Unit
2	Drive on Ramps
1	<u>Bolt Box that includes the following:</u>
16	Anchors for optional bolting to floor
8	Bolts, nuts, washers and lock washers for securing ramps
4	Bolts, nuts and washers for mounting power unit

Note: save packing bolts for installing top caps

Options:

Caster Kit with 4 caster pins

Jack Tray

Drip Tray

Important Notes

1. Always inspect the lift for damage and make note of any damage on the bill of lading.
2. In case of freight damage, call the truck line immediately and report the damage as a freight claim.
3. Always read the directions.
4. Do a thorough inventory of your parts and measure your cables.
5. Never raise a car until you have double-checked all bolts and nuts and hose fittings.
6. Always level and check for leaks. Never stand or store a car under this lift without the locks engaged.
7. Please obtain a qualified electrician to provide wiring in compliance with your local electrical codes.

Tools Required

1. Metric Open or box end wrenches
2. Metric socket set.
3. Large adjustable wrench.
4. Vise grips or locking pliers.
5. Large punch to align holes.

Make sure you have extra help or heavy duty lifting equipment when unloading and assembling. Make sure you have enough room to install the lock rods, at least a 9' clearance. The power unit may be installed on the driver's front corner or the passenger rear corner.

Installation Time

The lift should take between four and six hours to install.

Hydraulic Oil

Use AW-32 or ISO-32 hydraulic oil for your power unit. (10wt non-detergent hydraulic oil) DO NOT USE DEXTRON. It will damage the seals and shorten the life of your hydraulic components.

Floor Plan

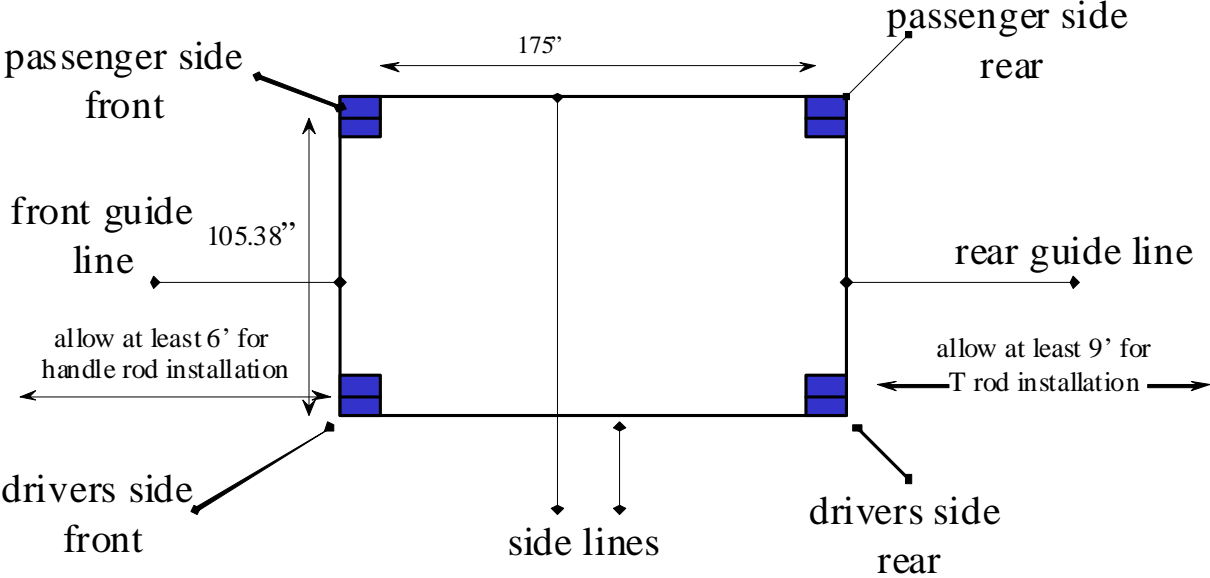

figure 1

BEFORE ATTEMPTING TO ASSEMBLE THIS LIFT STUDY FLOOR PLAN CAREFULLY. MAKE SURE YOU HAVE ENOUGH ROOM. KEEP FLOOR PLAN AREA CLEAR OF LIFT COMPONENTS UNTIL THEY ARE READY TO BE INSTALLED. TAKE SPECIAL NOTE OF SPACE NEEDED FOR SAFETY ROD ASSEMBLY

A.COLUMN AND CROSSBAR ASSEMBLY

1. Locate the four columns. One column has a bracket for the power unit. Determine placement of power unit column. (drivers side front or passenger side rear)**For this installation we will be placing the power unit in *the drivers side front position.***
2. Take column with the power unit bracket and stand it up in the *drivers side front* corner (see fig.1) with the opening facing in and the lock blocks located on the right side of the column opening (as you stand facing the opening) along the front guide line.
3. Stand up another column in *passenger side front* position. Make sure that the opening is facing in towards the *drivers side front* column and the lock blocks are on the left side of the column opening, along the front guide line.
4. Tilt the columns back and lay each on the ground along the side guide lines. Remove the top caps.
5. Place a crossbar at the top of the 2 columns. Be sure that the spring loaded lock latches at either end of the crossbar are facing up, with bevel side up.
6. With a helper slide the cross rail into the top of the columns. In order to lower the cross rail all the way down it will be necessary to manually hold the lock latches out of the way of the stop blocks. Release latches to engage the lowest lock blocks(16" off the ground). Stand the assembly up.
7. Repeat process for rear columns and cross rail. Make sure the lock blocks on the driver's side rear column are on the left of the column opening along the rear guide line, and that the lock blocks on the passenger side rear column are on the right side of the column opening along the rear guide line. When complete the cross rails will be approximately 160" apart.

B. TRACK INSTALLATION

1. Locate the track with the cylinder attached underneath. Now find the $\frac{3}{4}$ " hole in the side of the ramp. This hole will be positioned next to the power post (*driver's side front*). The ledge running down the side of the ramp always goes on the inside. (it's used to support the drip trays and other options)
2. To aid lifting, position the track on two 2x4s or blocks on the floor just outside the column assemblies taking care to keep ledge facing in.
3. With two people on each end of the track, lift the ends of the track onto the cross rails. You will need to walk one end at a time into the floor plan area to clear the column assemblies. Using a large punch, line up the holes in the cross rail with those on the track and temporarily bolt together using one bolt in each end.
4. Install offside track by repeating steps 1 through 3. Remember to keep the ledge running the length of track facing to the inside.
5. Locate the 4 drop-in ramp clips and working on one end at a time, carefully remove the track bolts, install the ramp clip, with spacing collars towards cross rail, and reinstall using both bolts and tighten.

C. CABLE INSTALLATION

1. Lay out all cables and measure from the inside of the button end to the end of the cable bolt to insure proper cable lengths. See fig.3 for measurements.
2. In order to attach the cable buttons to the mounting bracket on the end of the ram, the ram must be extended. Below are two suggested methods of extending ram
 - a. Using the cable mounting-bracket on the end of the ram, pull the ram out with a come-along.

- b. Position yourself under the track with you hands gripping the edge of the track, then put your feet against the cable bracket and push the ram out.

IMPORTANT: Take care not to score the ram when pulling the ram manually or tightening the nut. This will ruin the seal.

Since the nub end of the cable is easier end to feed through the pulley, start with the pulley at the end of the crossbar and work your way back to the ram. (Refer to fig 3 for cable routing.)

3. Install cable buttons into the appropriate slots in thick plate and secure with slots on thin plate. (see fig3a) Tighten enough so the nylock nut is fully threaded onto the head of the ram and that at least three threads are exposed past the top of the nut. The cable bracket should still be able to move freely on the ram head.
4. Run the threaded cable ends into the hole in the top caps and secure with washer and nylock nut.

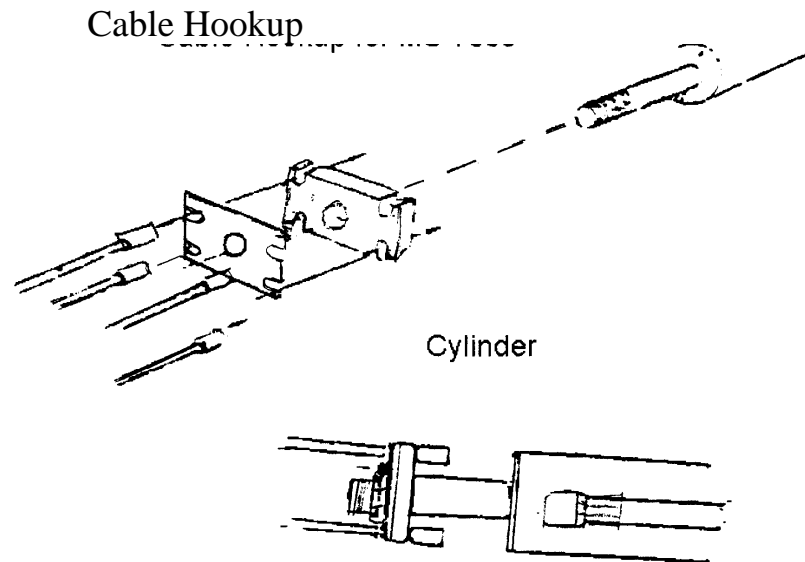

fig 3a

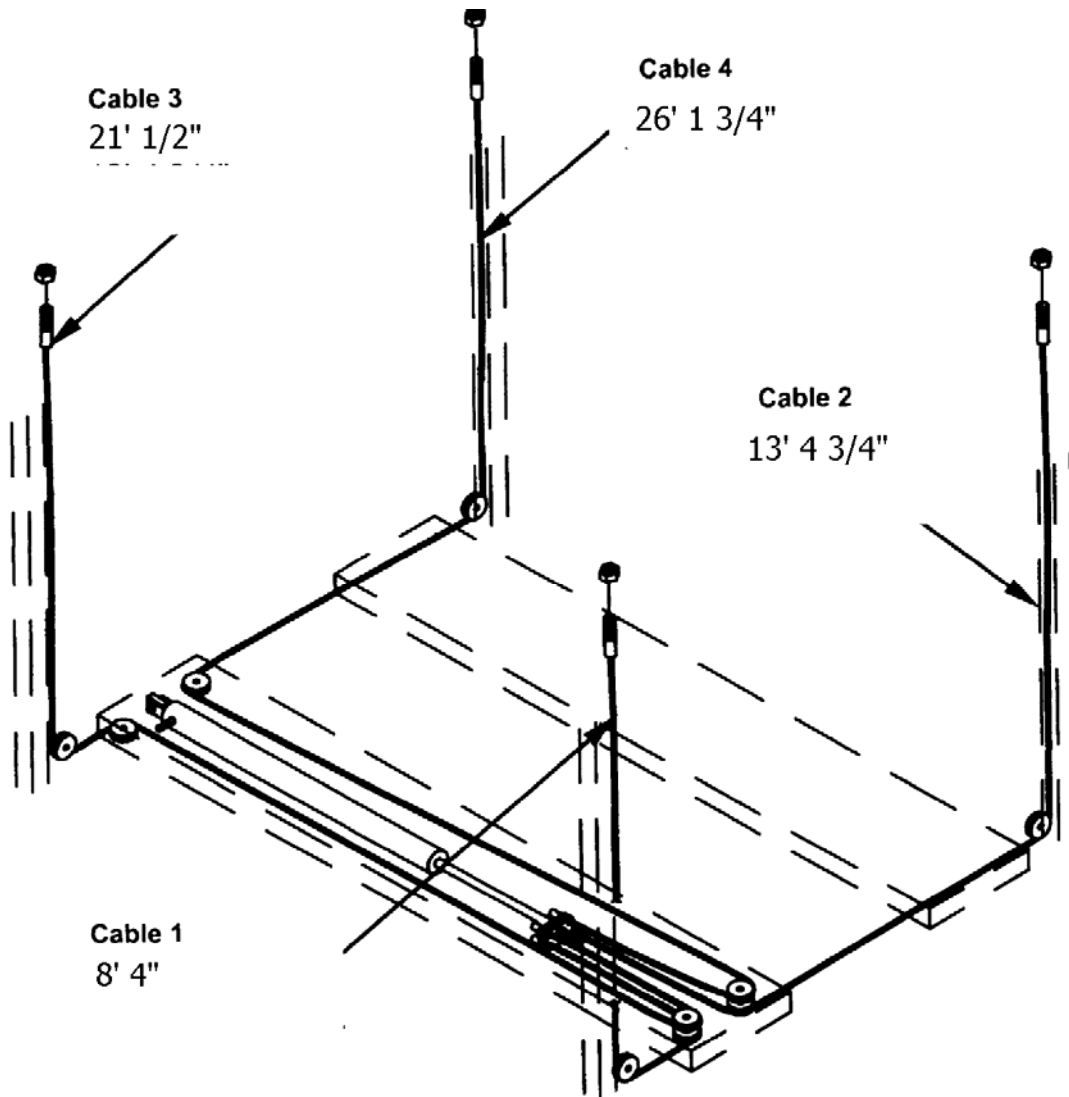

Figure 3

D. HYDRAULIC ASSEMBLY

1. Find the 4, 1" x 5/16" bolts, nuts and lock washers. With one helper holding the power unit, line up the holes on power unit with the holes in mounting bracket and attach with the four mounting bolts. Remove the plastic-cap from the port on the power unit and attach the o-ring elbow. Do not over tighten, backing nut and o-ring will complete seal.
2. Connect power unit hose (the hose with the spring on it) to the o-ring fitting on the power unit. Do not over-tighten.
3. On the end of the cylinder hose, located under the track, remove the backing nut from the bulkhead fitting, insert fitting through hole in side of track and secure with backing nut.

4. Attach loose end of power unit hose to the bulk head fitting
5. Use 3 gallons of ISO-32 or AW-32 hydraulic oil (can be purchased at local auto parts discount supplier) to fill reservoir (10wt non-detergent hydraulic oil)

F. LOCK LINKAGE ASSEMBLY

Remember: This manual is installing the power column at the driver's side front position

1. The single point safety lock is a system of connecting rods and linkage that disengage the four lock latches that secure the lift to each column. Locate the 6 rods:
2 long rods, 2 short rods, 1 handle, 1 tee.
2. Starting with the handle, insure that spacer is installed over threaded end of handle and inset rod into hole on cross bar near power column. Take care to run rod through rod guide located under track.
3. Install long rod into the hole on the cross rail near the driver's rear column. Make sure the spacer is on the rod and take care to run rod through rod guide.
4. Thread nut onto ends of handle rod and "T" rod. With the T on the handle set at 12:00 o'clock and the T on the long rod set at 12:30 when viewed from power unit end, attach coupler and tighten with lock nuts. Rod should be secure but free enough to swing.
5. Starting at the power unit end, attach linkage bolt at one end of the long 1/4" rod into the hole located in the lock latch near the passenger front column and secure with nut. Attach the other end of the long 1/4" rod to the top of the handle T
6. Repeat using short 1/4" rod attaching to the lock latch near the driver's side front column and attach the other end to the bottom of the handle T
7. Repeat process on rear cross rail.

G. FINAL ADJUSTMENTS

1. Depress power up button for 10 seconds. Then while continuing to hold power button open release lever for another 5-10 seconds, allowing air to be bled from the system.
2. Run power until tracks begin to rise. Go to the top of each column and tighten any cables that are slack. All cables should have even tension and platform must hang level. (Check by using a level on the crossbars). Never adjust cables with a vehicle on the lift. This will damage threads on cable.
3. Run lift up and down a few times to insure that the locks are engaging uniformly and that the release mechanism is functioning properly. Have helper check to be sure that far side lock latches are disengaging as fully as the near side lock latches
4. With lift all the way down, install the approach ramps and carefully drive a vehicle onto the tracks.
5. Run the lift up and down a few times rechecking all function. If cables need to be adjusted vehicle must be removed first or damage to threads on cable will occur.



TX FP9K

Kernel Edition 1.0

Mar.2008

KERNEL ITEM NO.163012<DPF4-3.2K>

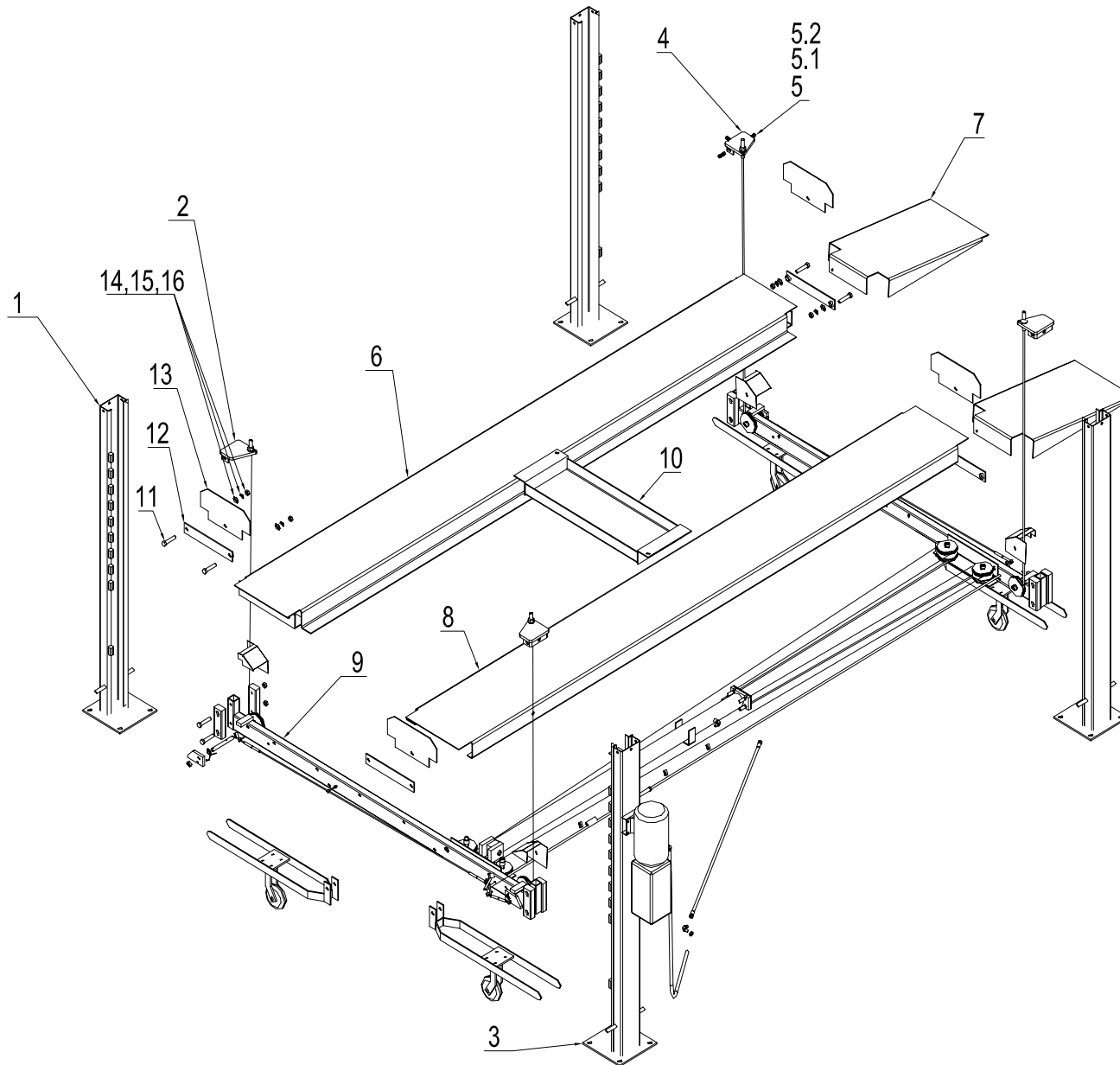

Spare Parts List

ITEM	DESCRIPTION	QTY
1	Column parts	2
2	Top Plate parts	2
3	Column parts	2
4	Top plate parts	2
5	Galvanized bolt	12
5.1	Flat washer	24
5.2	Galvanized nut	12
6	Punway parts	1
7	Brae	2
8	Punway parts	1
9	Cross beam parts	2
10	Toolbox parts	1
11	Bolt	8
12	Rub blocks	4
13	Ramp broad	4
14	Galvanized flat washer	8
15	Spring washer	8
16	Galvanized nut	8

* Easily Worn Parts



TX FP9K

KERNEL ITEM NO.163012<DPF4-3.2K>

Kernel Edition 1.0

Mar.2008

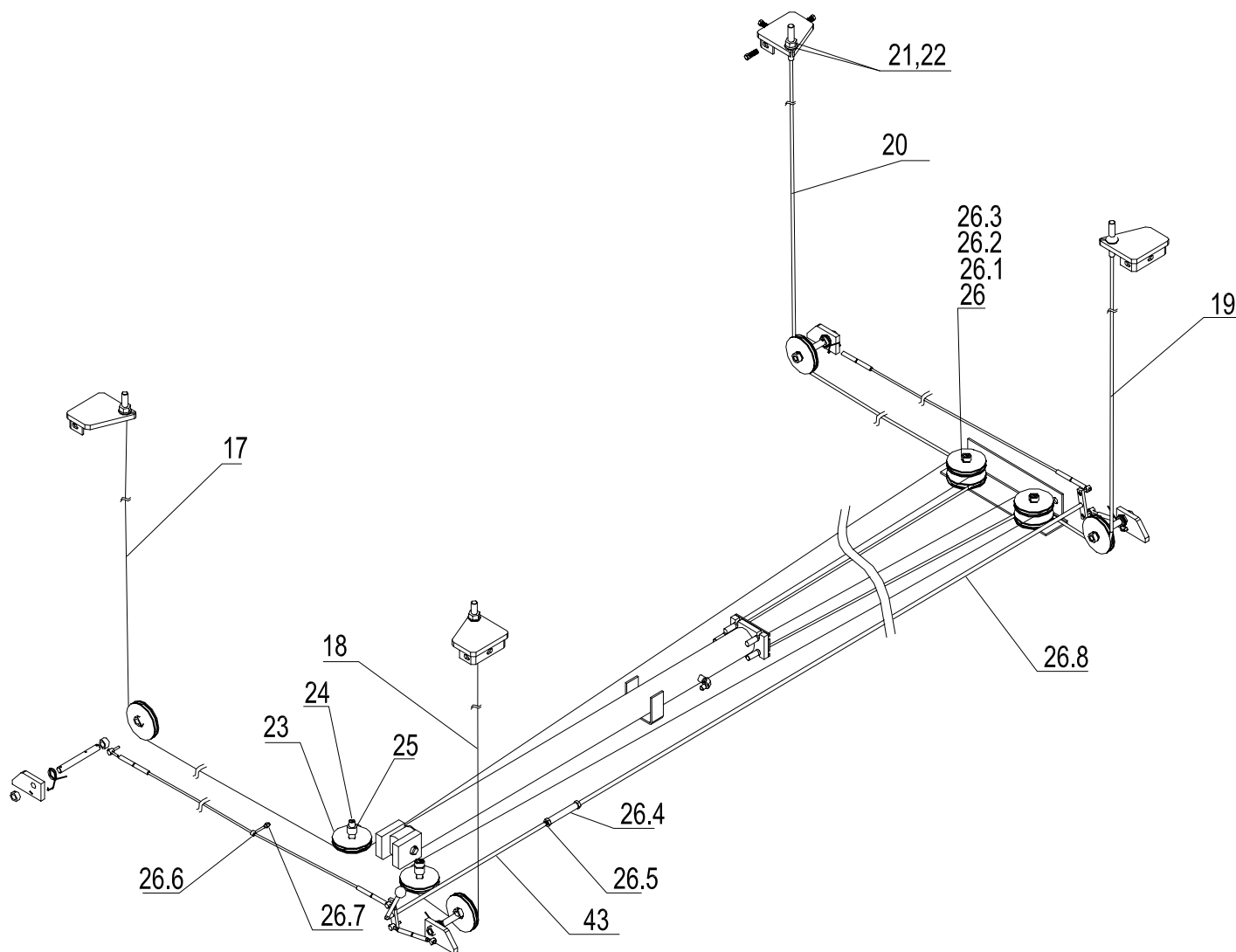

Spare Parts List

ITEM	DESCRIPTION	QTY
17	Steel cable	1
18	Steel cable	1
19	Steel cable	1
20	Steel cable	1
21	Lock nut	4
22	Flat washer	4
23	Pulley	10
24	Core shaft	4
25	Sheath	2
26	Sheath	2
26.1	Flat washer	6
26.2	Bush	6
26.3	Bolt	4
26.4	Aunectent shaft	1
26.5	Galvanized nut	2
26.6	Bolt	2
26.7	Galvanized nut	2
26.8	Up-rights	1
43	Untie lock handle	1

* Easily Worn Parts



TX FP9K

Kernel Edition 1.0
Mar.2008

KERNEL ITEM NO.163012<DPF4-3.2K>

Spare Parts List

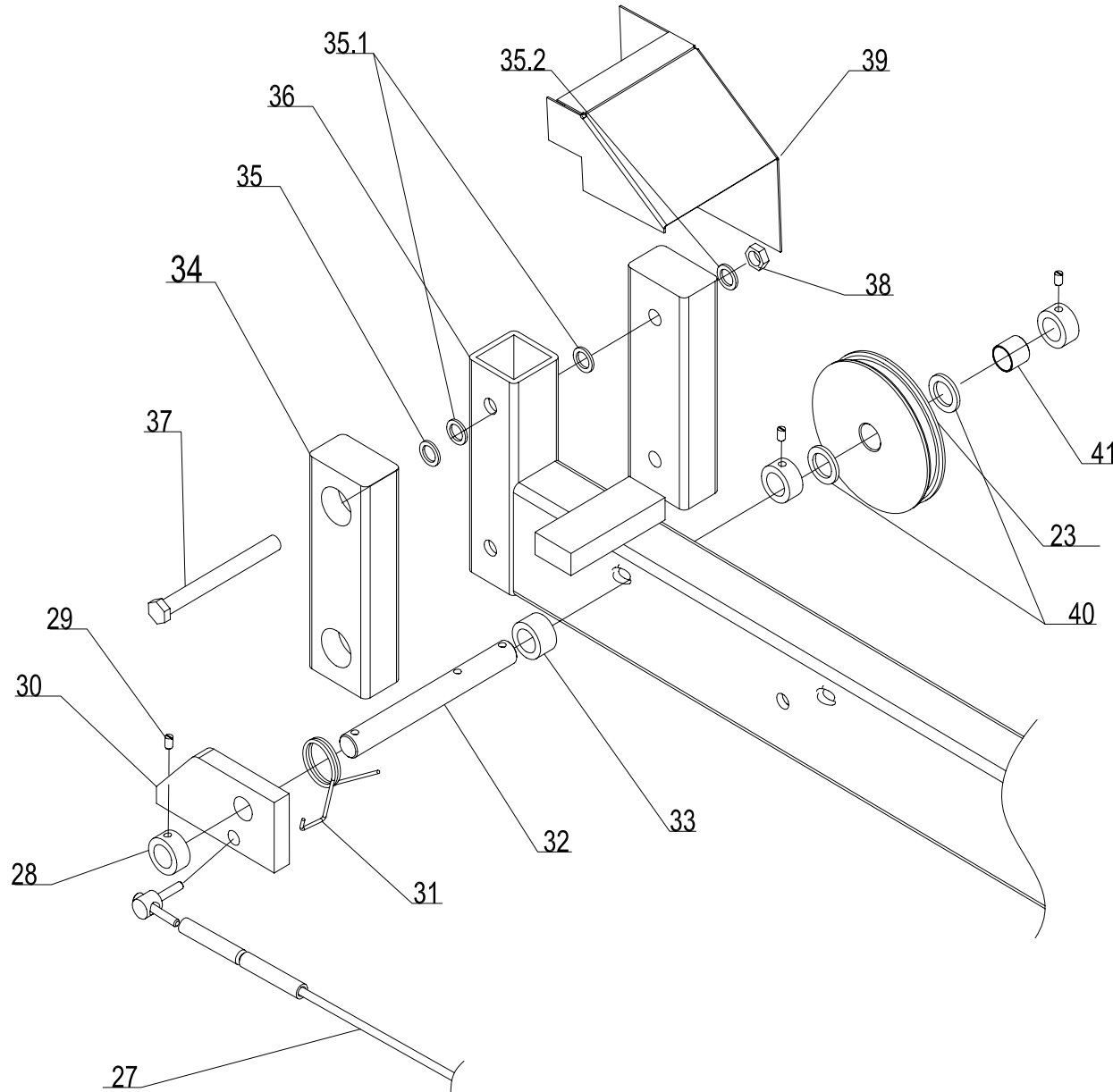

ITEM	DESCRIPTION	QTY
23	Pulley	10
27	Pole	2
28	Sheath	8
29	Bolt	12
30	Retopack bolt	4
31	Wrest spring(right)	2
32	Bushing	4
33	Spring sheath	4
34	Rubber block	8
35	Washer	32
35.1	Flat washer	16
35.2	Flat washer	24
36	Cross beam parts	2
37	Galvanized bolt	8
38	Galvanized nut	8
39	Cover A	2
40	Flat washer	12
41	Bush	4

* Easily Worn Parts



TX FP9K

KERNEL ITEM NO.163012<DPF4-3.2K>

Kernel Edition 1.0
Mar.2008

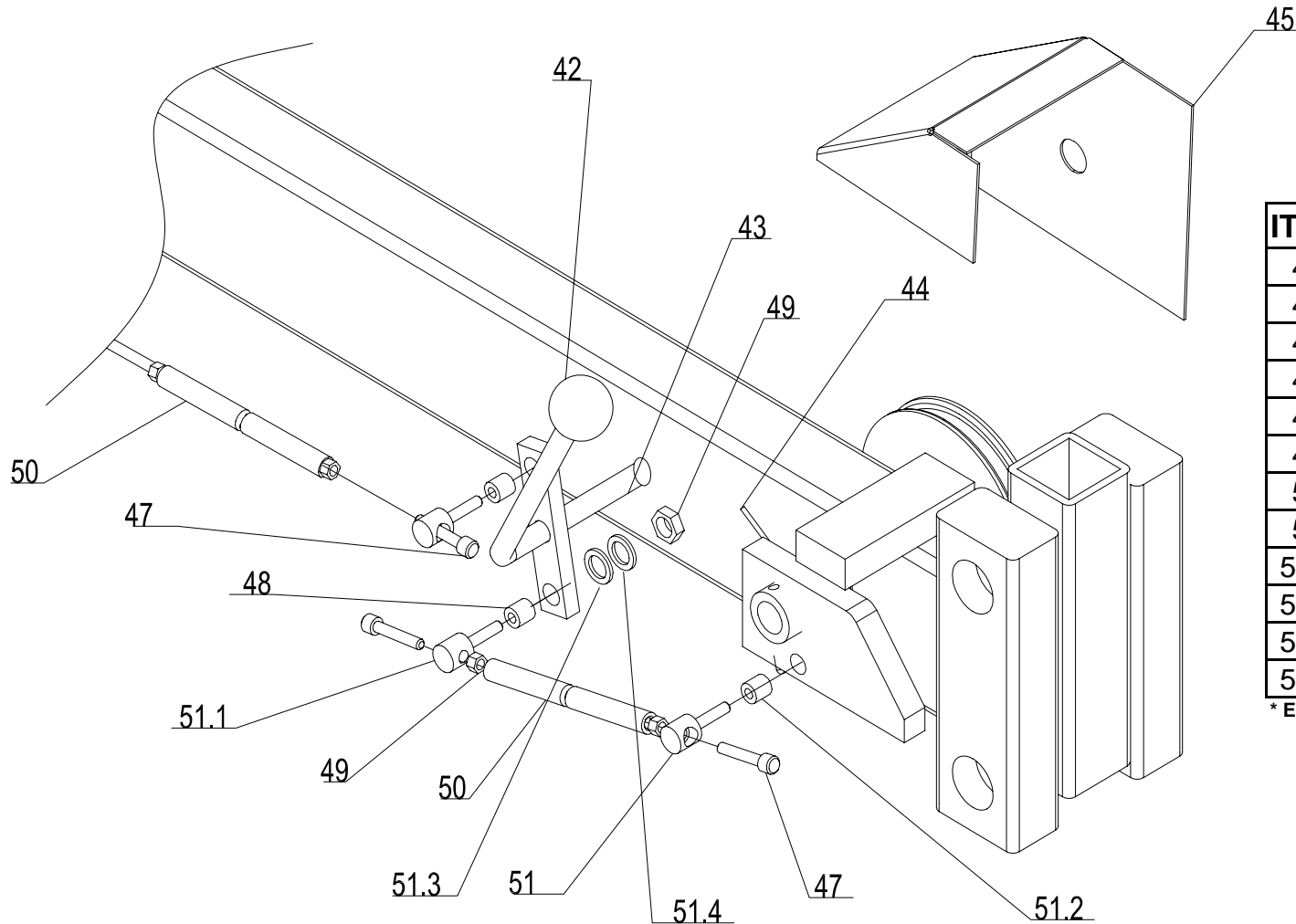

Spare Parts List

ITEM	DESCRIPTION	QTY
42	Bakelite ball	1
43	Untie lock handle	1
44	Wrest spring(left)	2
45	Cover B	2
47	Bolt	8
48	Cover	4
50	Bushing	6
51	Small shaft	4
51.1	Small shaft	4
51.2	Cover	4
51.3	Flat washer	8
51.4	Spring washer	8

* Easily Worn Parts

Page 4 of 5



TX FP9K

KERNEL ITEM NO.163012<DPF4-3.2K>

Kernel Edition 1.0
Mar.2008

Spare Parts List

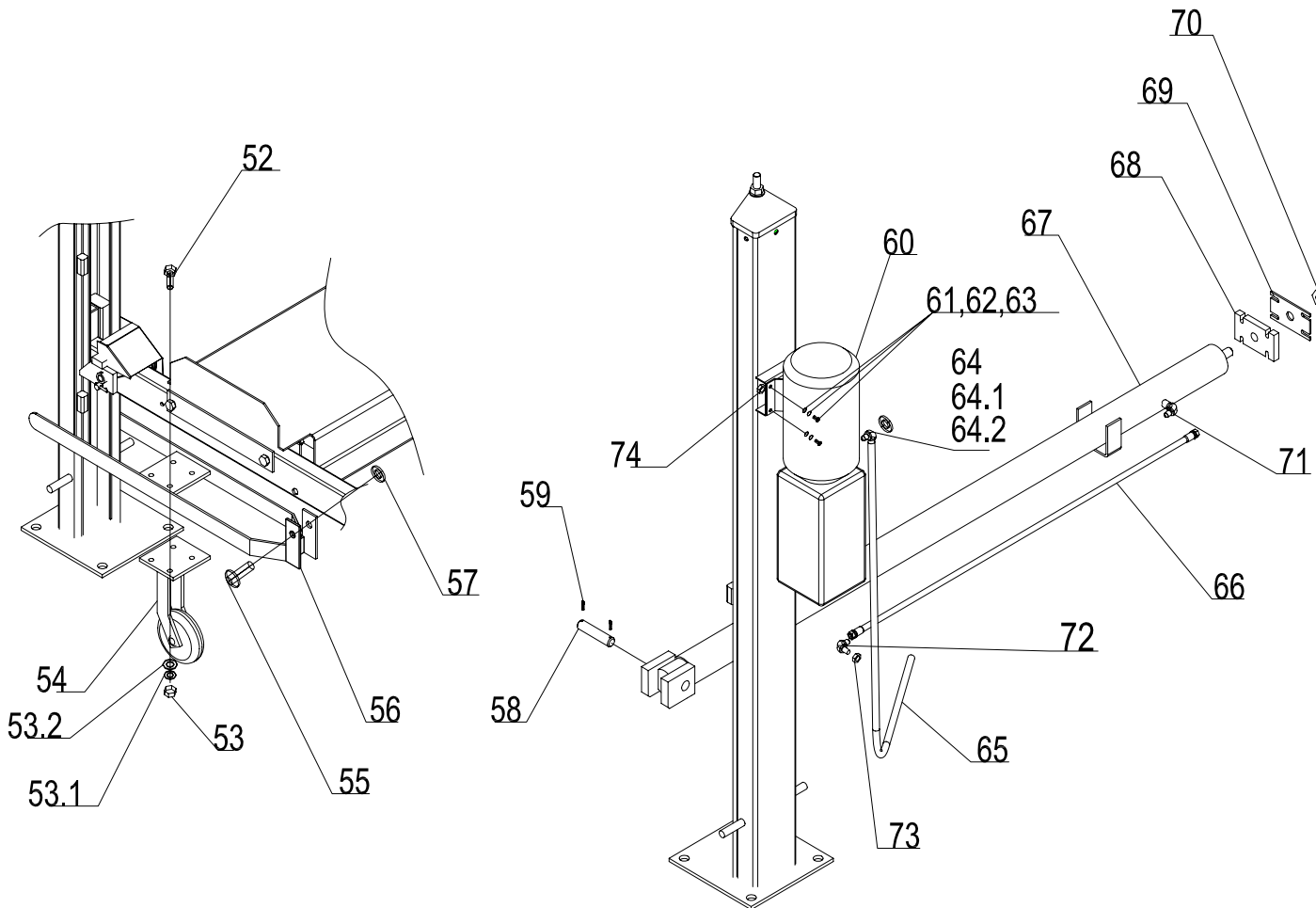

ITEM	DESCRIPTION	QTY
52	Galvanized bolt	16
53	Galvanized nut	16
53.1	Spring washer	16
53.2	Flat washer	16
54	Caster	4
55	Raw pin	4
56	Plank parts	4
57	Spring block	4
58	Hydraulic cylinder pin	1
59	Shaft sheath	2
60	Hydraulic pump	1
61	Flat washer	8
62	Spring washer	4
63	Galvanized bolt	4
64	Right-angled Tie-in	1
64.1	Hydraulic extention	1
64.2	Bushing	1
65	Oil hose	1
66	Oil hose	1
67	Hydraulic cylinder	1
68	Wheel stop plates	1
69	Front of wheel stop plates	1
70	Locknut	1
71	Right-angled Tie-in	1
72	Right-angled Tie-in	1
73	Nut	1
74	Galvanized nut	4

* Easily Worn Parts